

Beton Blocks

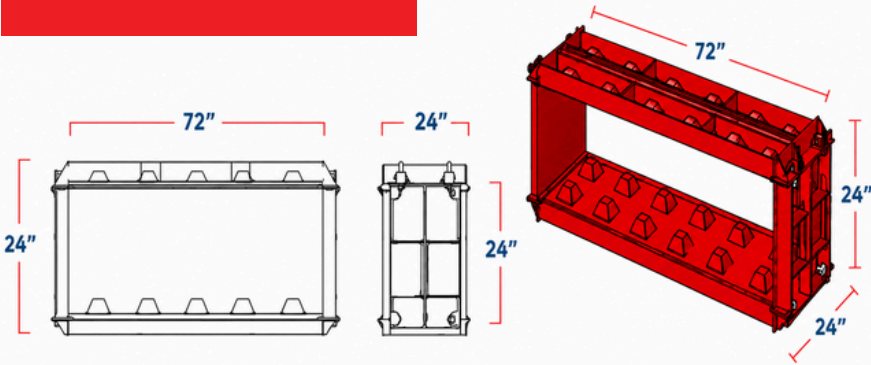

BETON BLOCK



Diagrams reference only

SPECIFICATIONS

Dimensions	72" x 24" x 24"
Half Block Available	36" x 24" x 24"
Volume	0.89 cu yd
Weight	580 lbs
Output Weight	3400 lbs

OUTPUT WEIGHT
3400 lbs*
1700 lbs*
(HALF)

FEATURES

Heavy Duty Stability

Designed to maintain structural integrity under heavy loads and challenging site conditions.



Easy-to-Connect Interlocking System

Built for simple stacking to create an interlocking wall.



APPLICATIONS

- Construction Walls & Barriers
- Bulk Material Storage
- Building Foundations & Base Structures
- Dock & Port Infrastructure

They offer the perfect solution for organizing materials and creating sturdy boundaries with strength and stability.



Repurpose Aggregates, MD

Our beton blocks are created exclusively with material from Repurpose Aggregates.

Our beton blocks are first rate high quality - built to sustain 4,000 PSI.

